

Processing gradients of magnetic data utilizing an equivalent source technique

Ruizhong Jia and Ross Groom,
PetRos EiKon, Brampton, Ontario, Canada

TOPICS

- Introduction
- Motivation
- FFT Derivatives
- Equivalent Source Techniques
- First Synthetic Example
- Second Synthetic Example
- Third Synthetic Example
- Conclusions

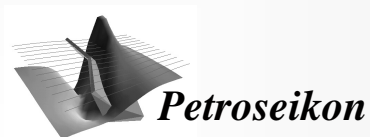

Generating derivatives - motivation

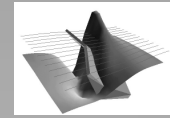

- The issue of generating all three gradients of total magnetic field is fundamental.
- If the 3 gradients can be generated accurately then most other processing techniques may be applicable.
- FFT is a commonly utilized technique to generate gradients of a potential field.
- we utilize an equivalent source technique (ES) to generate gradients.

Generating derivatives with FFT - procedure

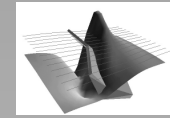

Set up FFT grid



Grid data utilizing commonly used interpolation techniques such as:

- **Minimum curvature**
- **Natural neighbor**



Compute derivatives utilizing forward and inverse FFT

Assuming that $\phi(x, y, z)$ is harmonic, that is,

$$\frac{\partial^2 \phi}{\partial x^2} + \frac{\partial^2 \phi}{\partial y^2} + \frac{\partial^2 \phi}{\partial z^2} = 0, \text{ then}$$

$$F\left(\frac{\partial f}{\partial x}\right) = (ik_1)F(f)$$

$$F\left(\frac{\partial f}{\partial y}\right) = (ik_2)F(f)$$

$$F\left[\frac{\partial \phi}{\partial z}\right]_{(x,y,z_0)} = \left(\sqrt{k_1^2 + k_2^2}\right)F[\phi(x, y, z_0)]$$

Equivalent Source - motivation

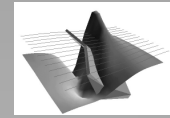

- **FFT derivatives involves gridding by interpolation, forward and inverse Fourier transform and utilizing tapering windows.**

FFT derivatives are affected by all factors.

- **Edge effects with FFT.**
- **Elevation variation of sensor may introduce noise**
- **Equivalent Source (ES) an alternative method**

Equivalent Source - experience

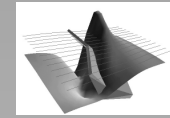

- FALCON utilizes ES technique (Dampney (1969)) to convert measured airborne gravity gradient to other gravity components (vertical gravity, tensor elements)
- **Jia and Groom (SEG2005) utilized ES technique to generate derivatives of gravity data.**
- **Applying initial approach to magnetic data led to inconsistent results. Likely due to faster falloff of inherent Greens function.**
- **The distance between the observational surface and the equivalent layer of susceptibility is a critical factor in generating derivatives of total magnetic field.**
- **imposing the smoothness of the inverted models helped improve the derivatives.**

Equivalent Source - inversion grid setting

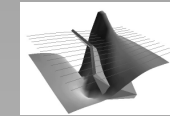

ES technique is based on a 3D inversion.

We utilize only one layer of cells.

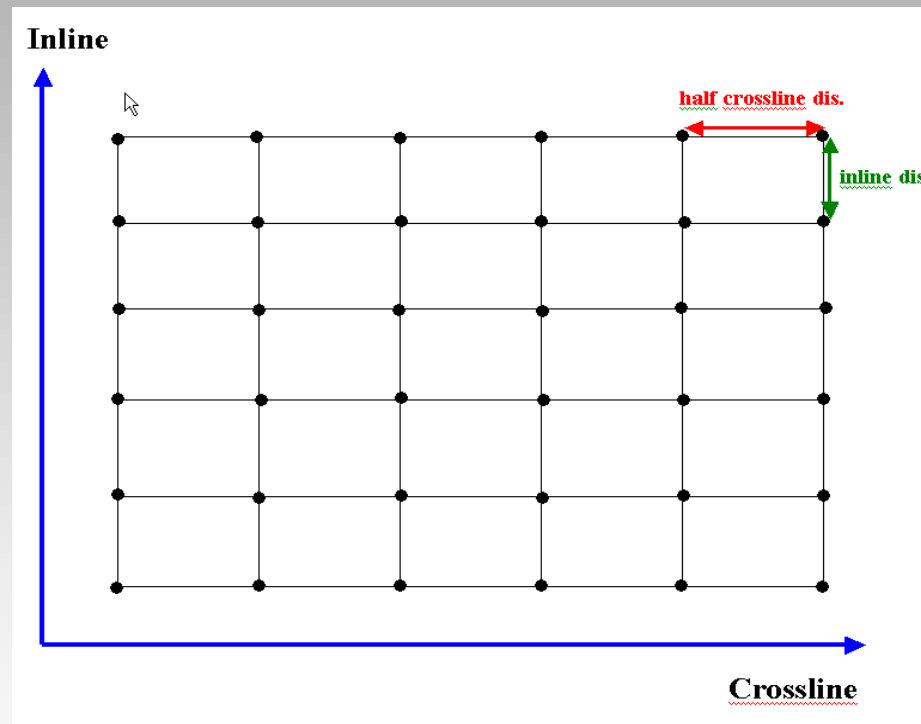

During the inversion, the equivalent layer is shifted downward until the data misfit exceeds the specified target misfit value.

Equivalent Source – imposing smoothness

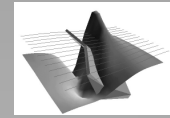

To impose smoothness of the inverted model:

- The nodes of the cells are assigned an unknown susceptibility.
- Cell susceptibility is the sum of 4 corner nodes

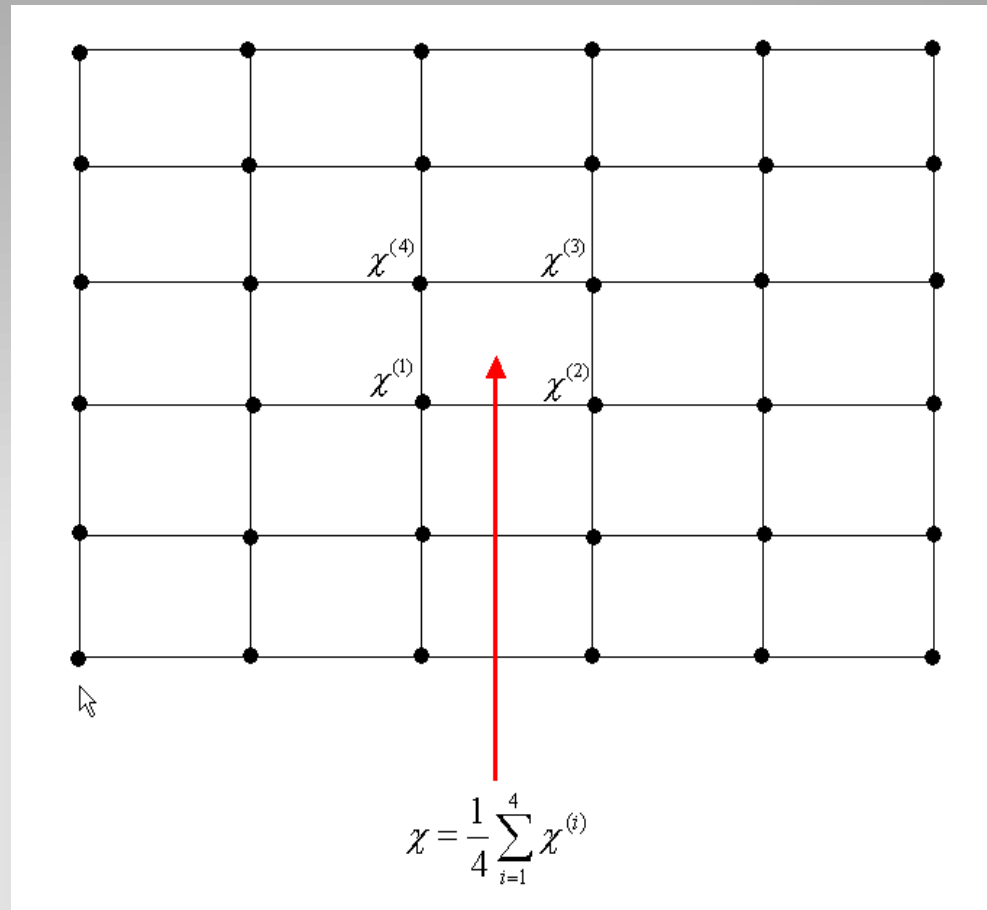

Model 1: Dyke

depth to top – 50m

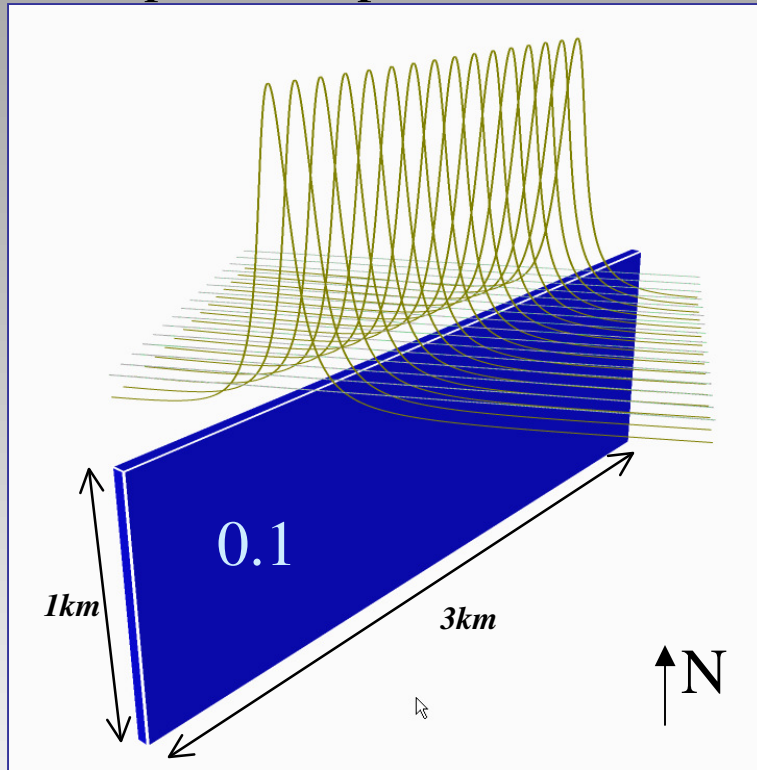

*line spacing – 100m
data spacing – 4m*

*inclination 75 degrees
declination 20 degrees east*

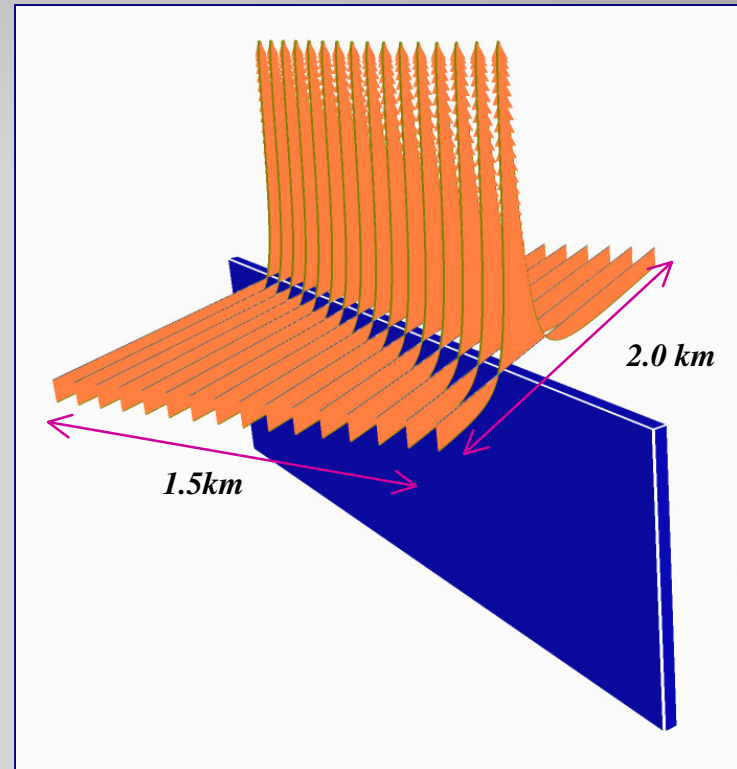

Response of dyke

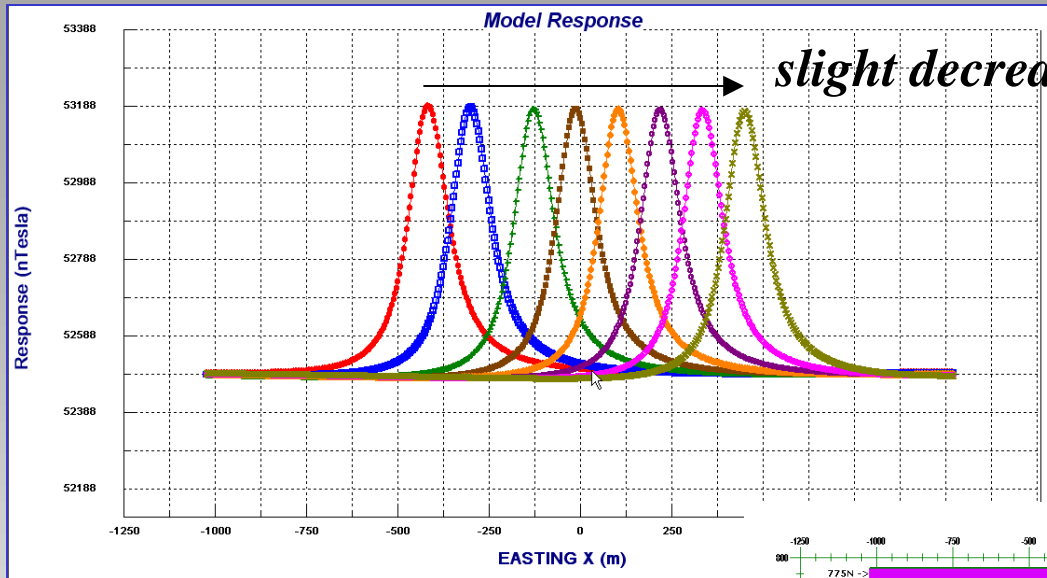

model response on FFT grid
by minimum curvature

Grid for FFT

512 x 32

4m x 50m

every other grid line on profile

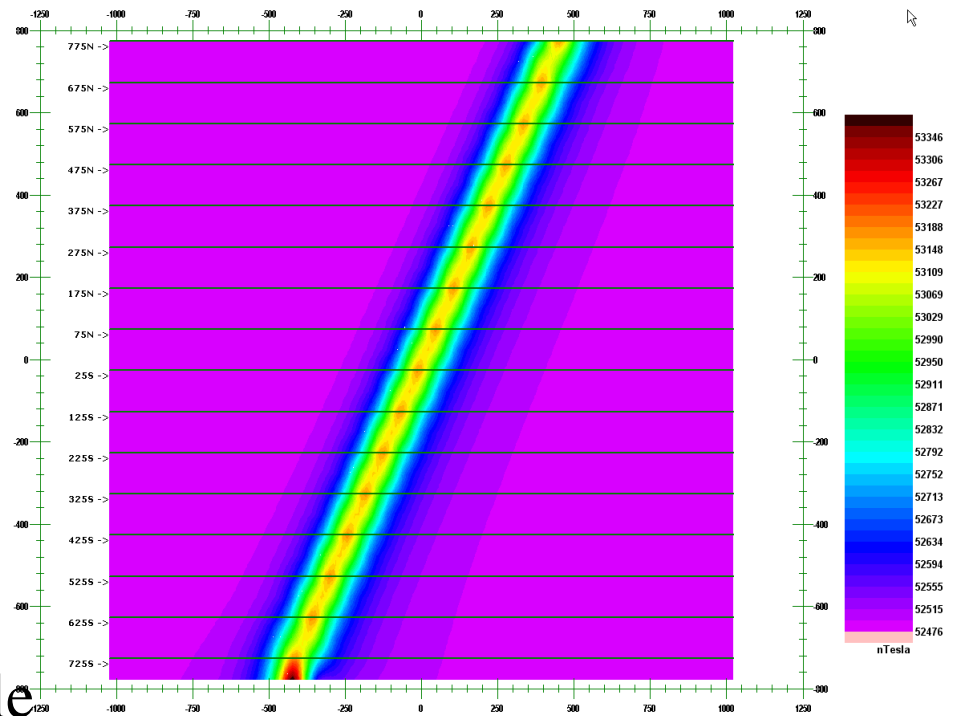

Comparison Procedure

1. *Interpolate 16 lines of data at 4m sample spacing (8192 data points) onto a regular grid 4m x 50m (512 x 32) via Minimum Curvature*
2. *Derive 3 derivatives by FFT using various amounts of internal tapering*
3. *Derive 3 derivatives by equivalent source inversion utilizing original 8192 data points*
4. *Produce new survey grid utilizing FFT grid nodes and re-simulate original model as well as equivalent source model*

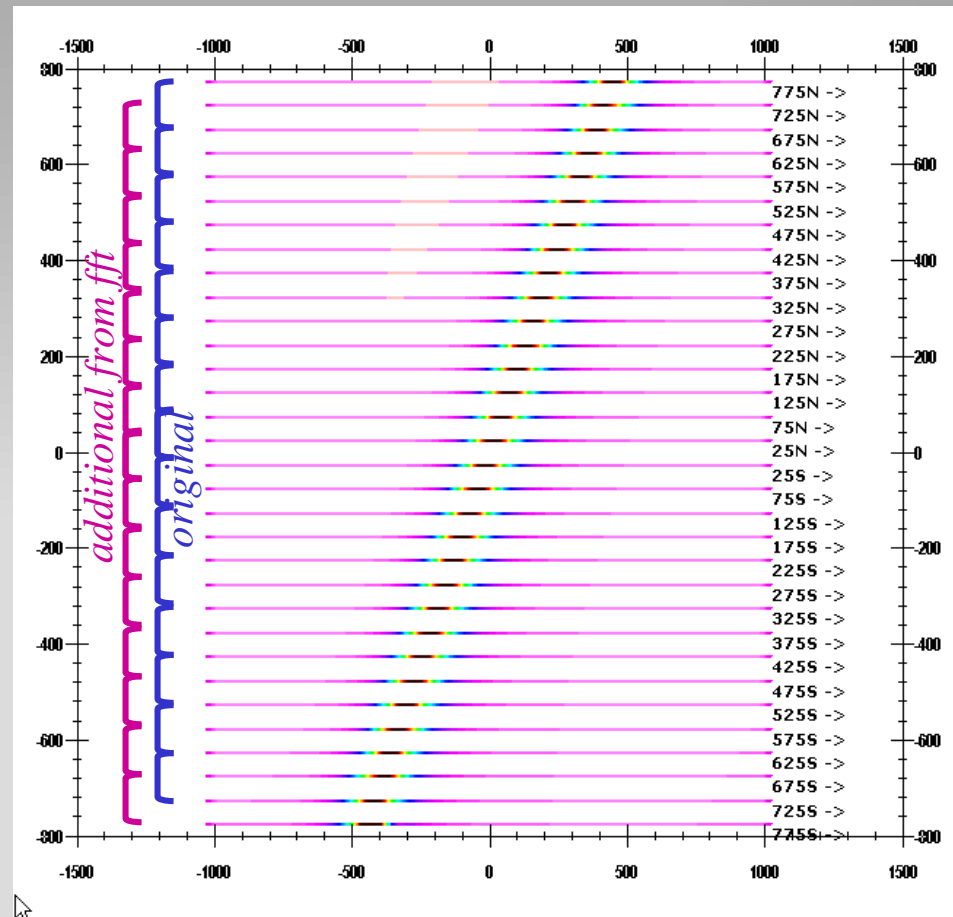

Inline Derivatives

derivative along original survey line

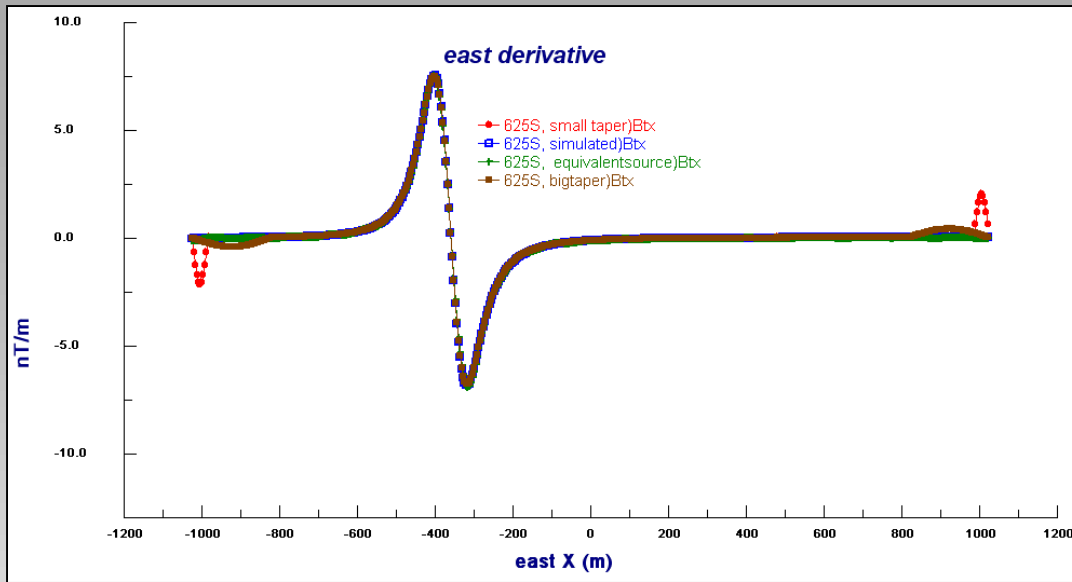

“True” simulated data in blue
FFT derivative with 10% taper in red
FFT derivative with 20% taper in brown
Equivalent source(ES) derivative in green

over original survey line, little to differentiate techniques expect at end of line where we note normal edge effects via FFT whereas ES has no such effects

derivative along interpolated lines

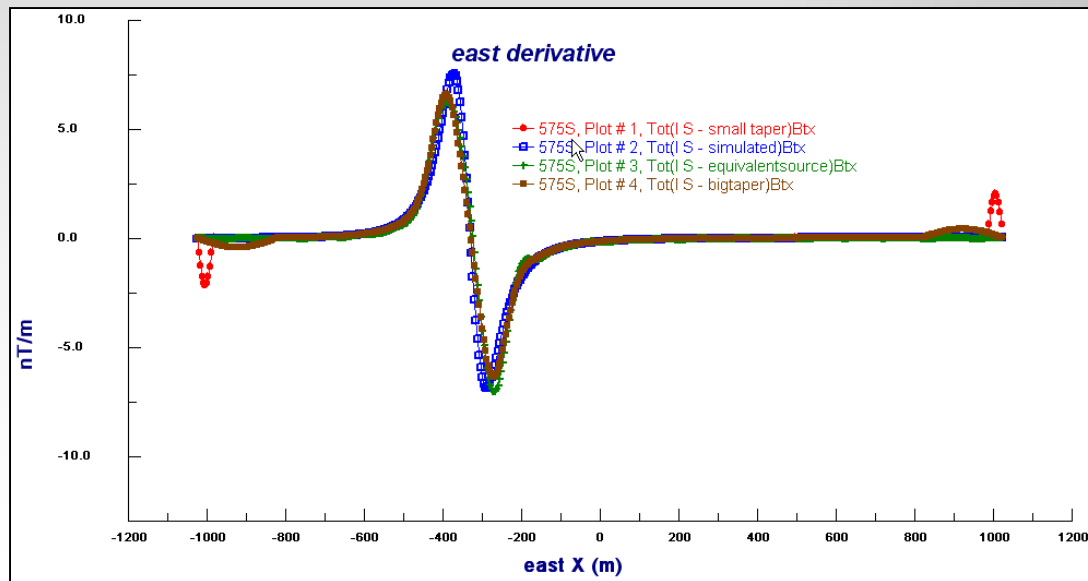

the reproduced derivatives by FFT and ES, are not as accurate as over the original lines
The main improvement of the ES is again the lack of edge effects

derivative along original survey line at edge

Inline and crossline Derivatives

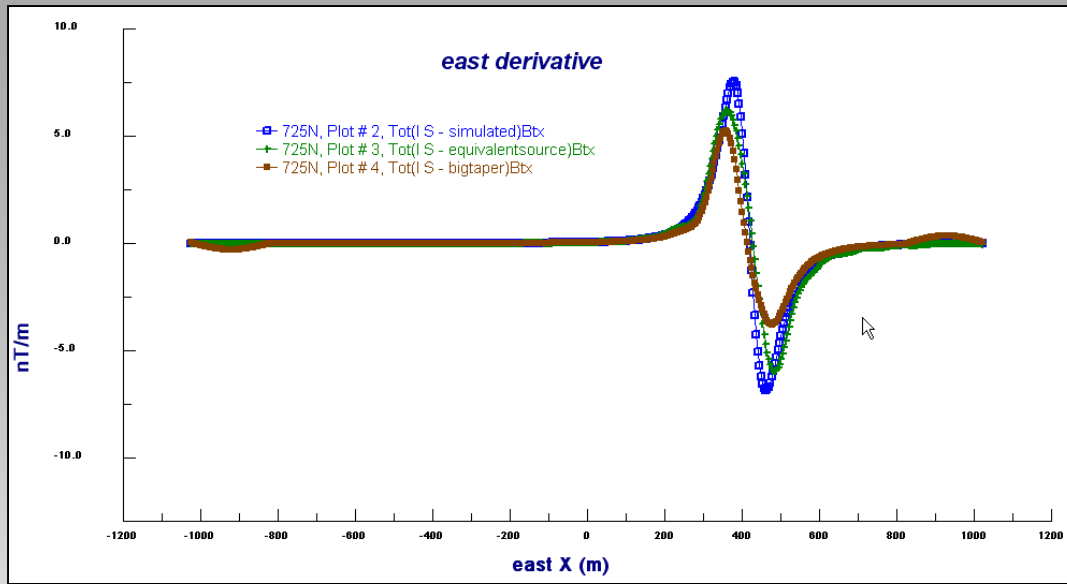

as we move to the northern edge, the effect of tapering on the FFT reduces the amplitude and now the ES technique is clearly better

derivative perpendicular to survey lines

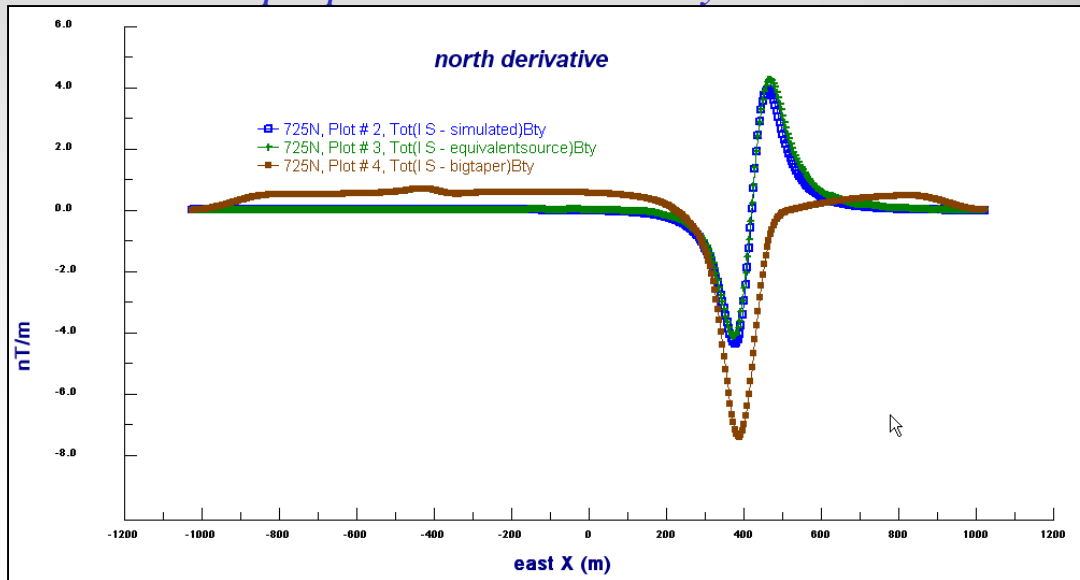

for the crossline or north derivative, the ES now provides a very significant improvement

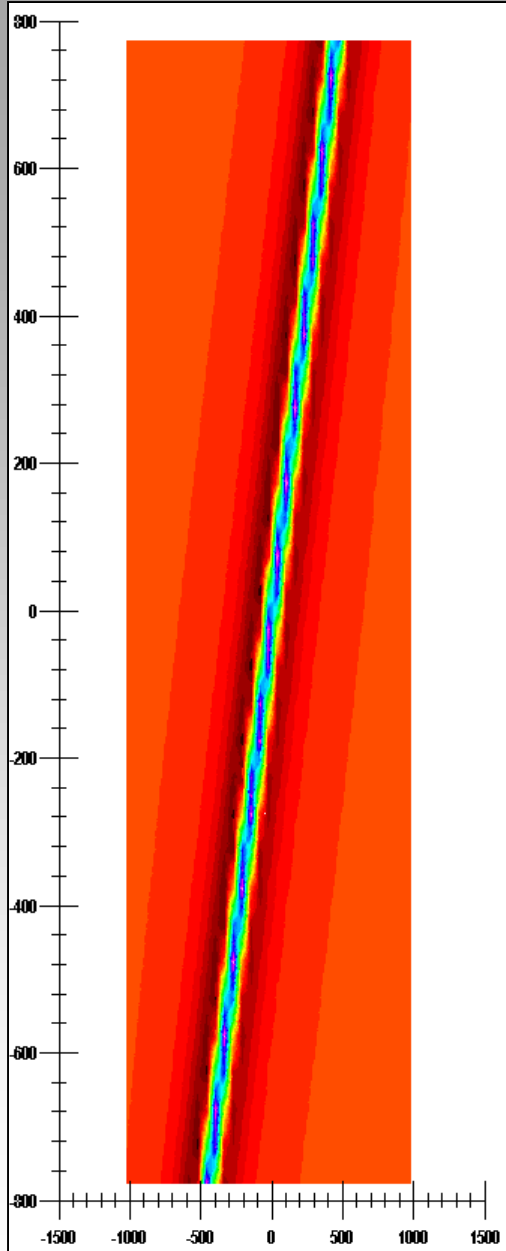

vertical derivative original

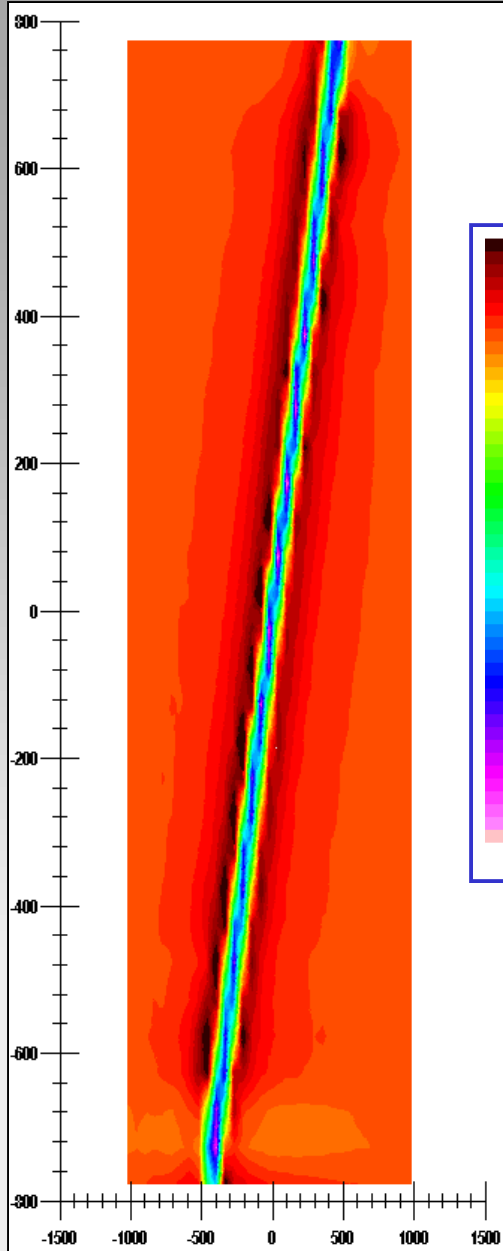

vertical derivative ES

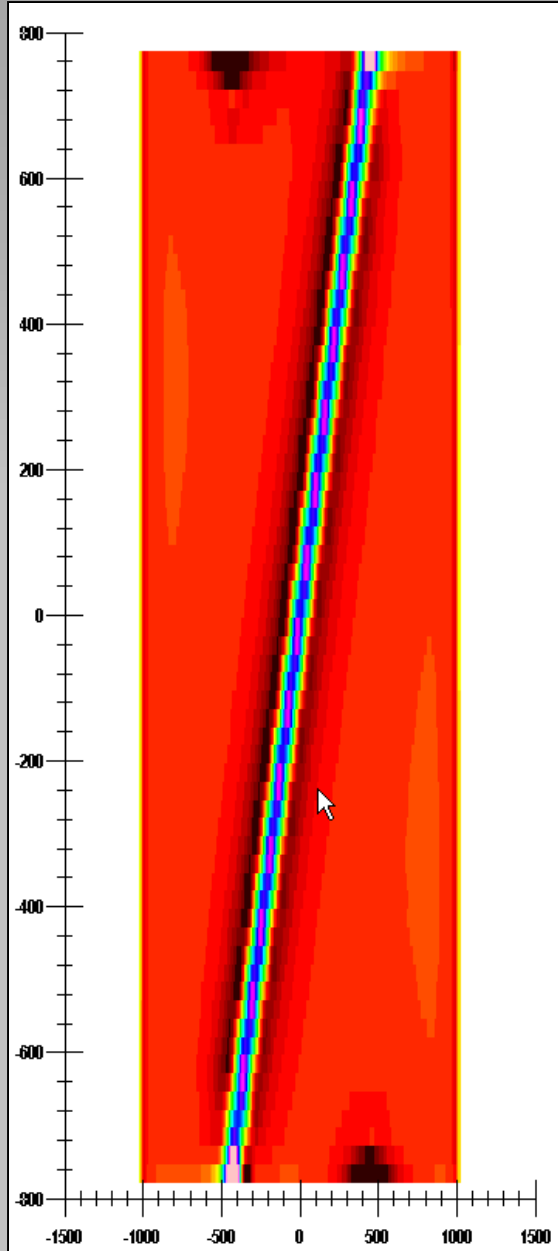
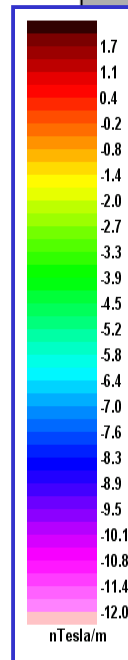

vertical derivative FFT

Deep Target

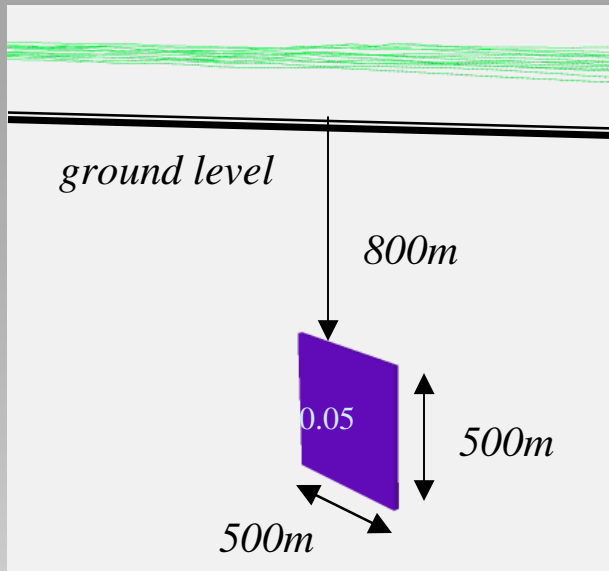

*sensor height
62m to 122m)
average 82m*

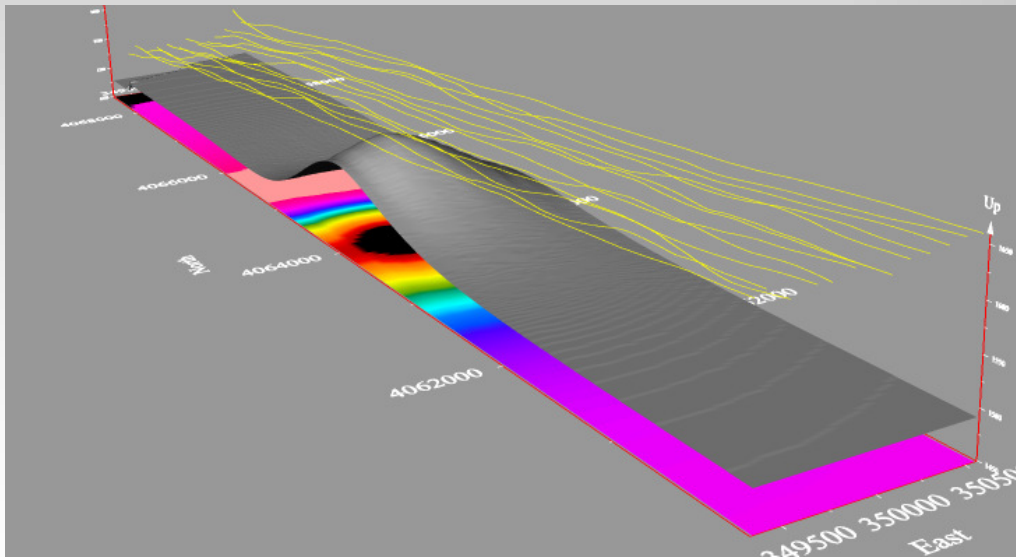
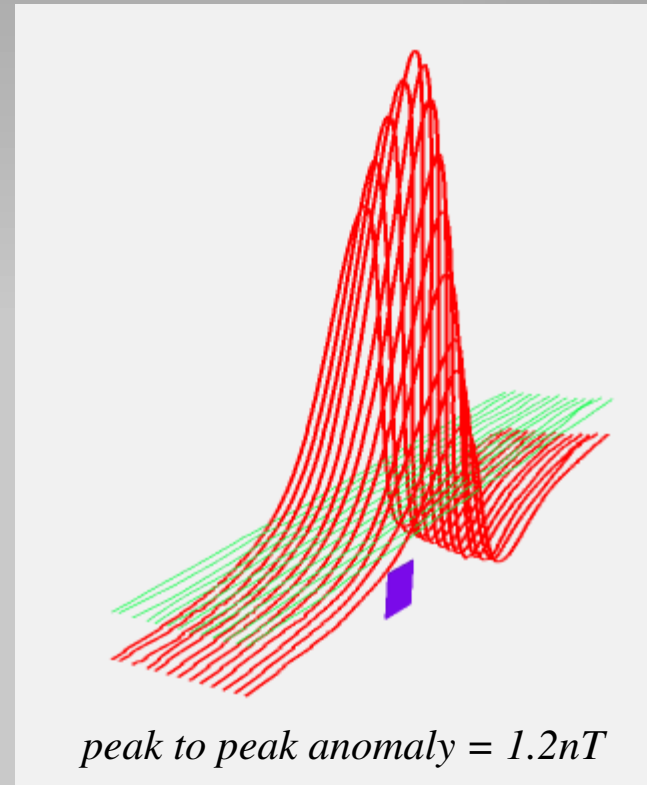

Deep Target Inline Derivative

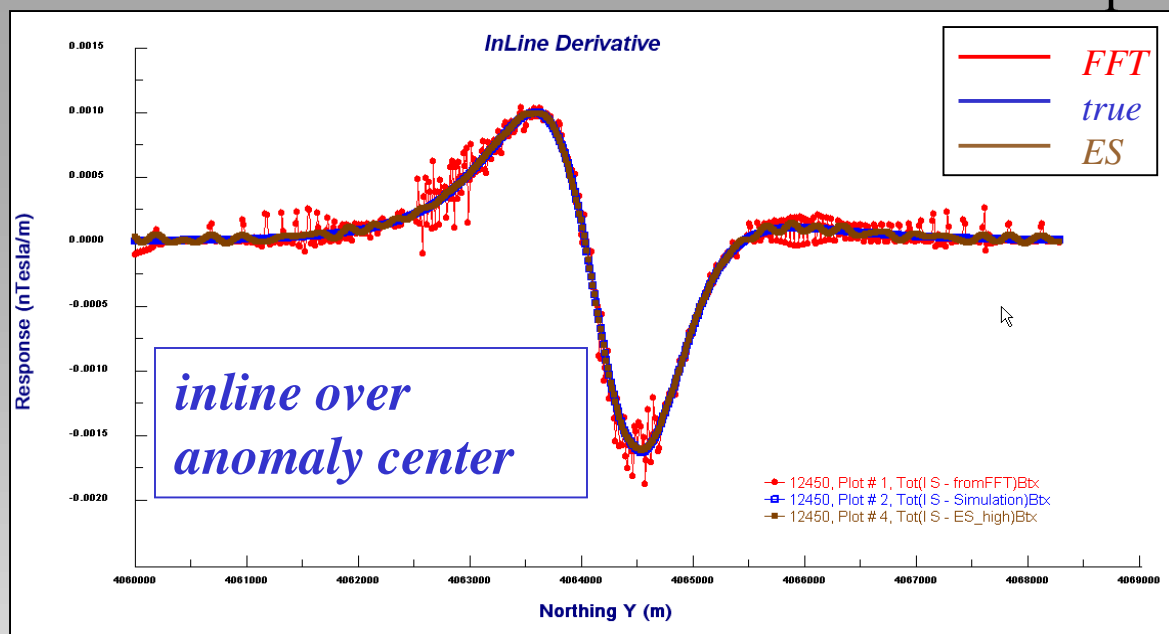

*FFT noise:
elevation variation
interpolation*

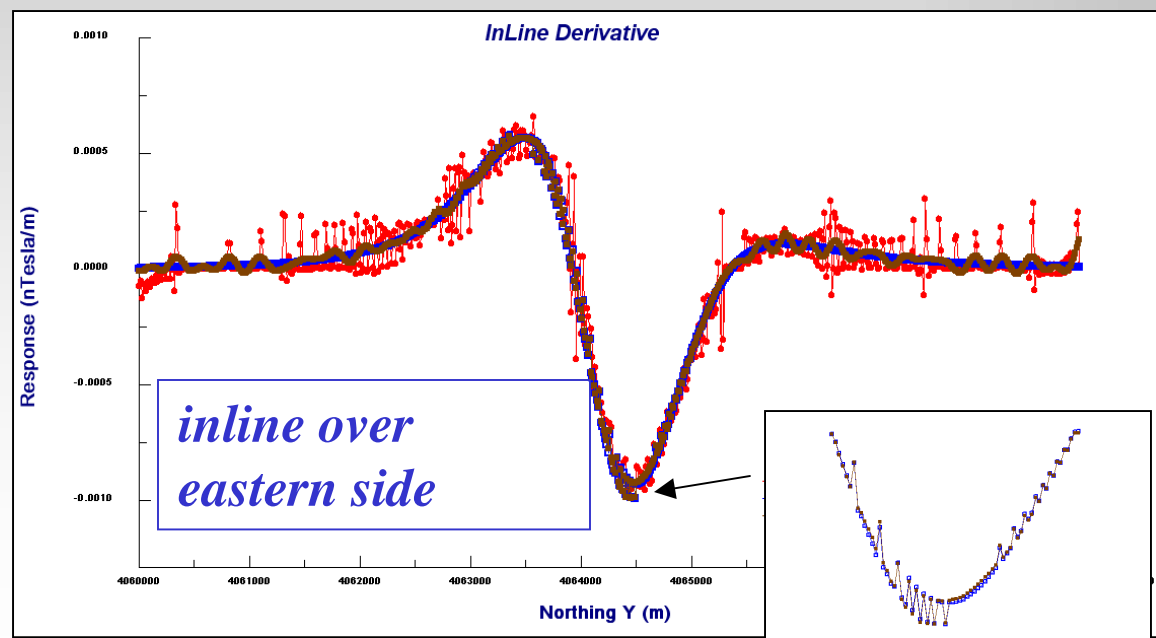

Deep Target Crossline Derivative

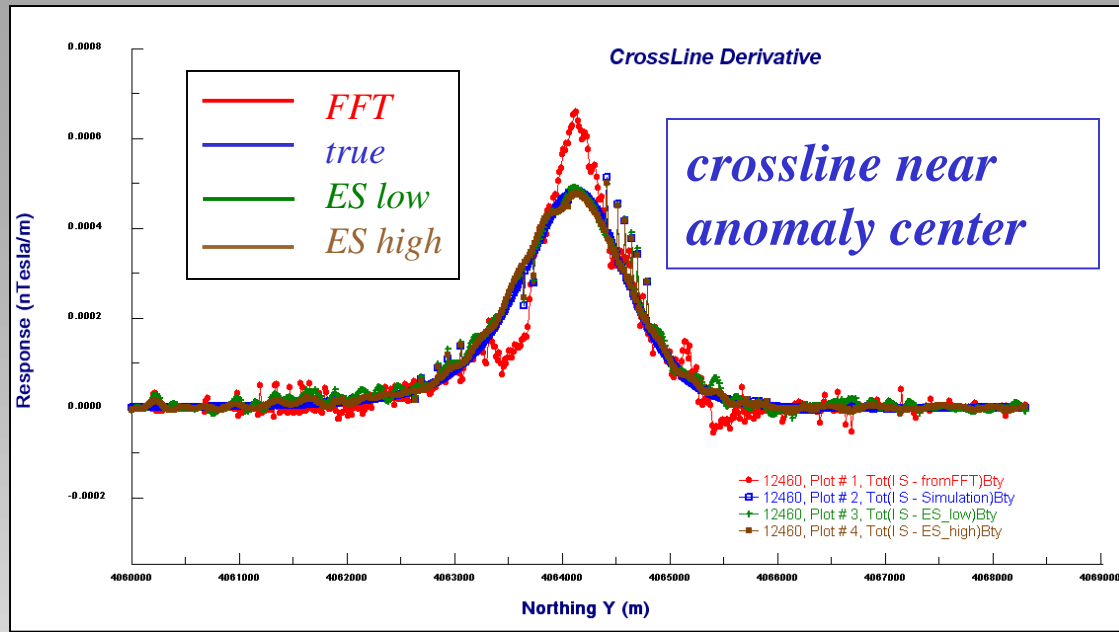

*FFT noise:
elevation variation
interpolation*

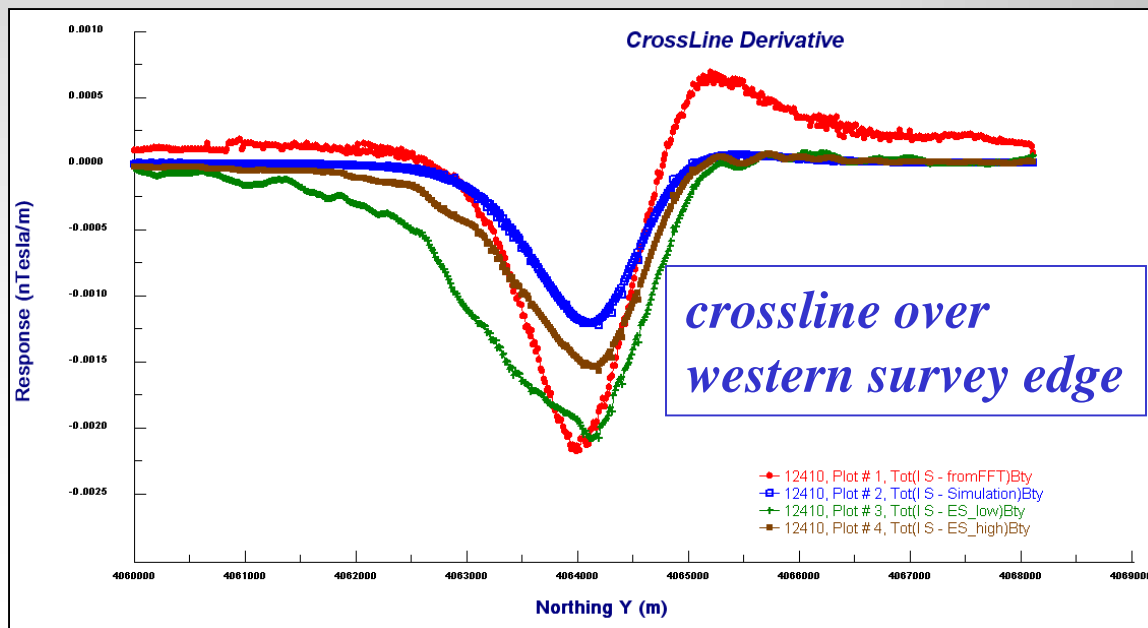

Deep Target Vertical Derivative

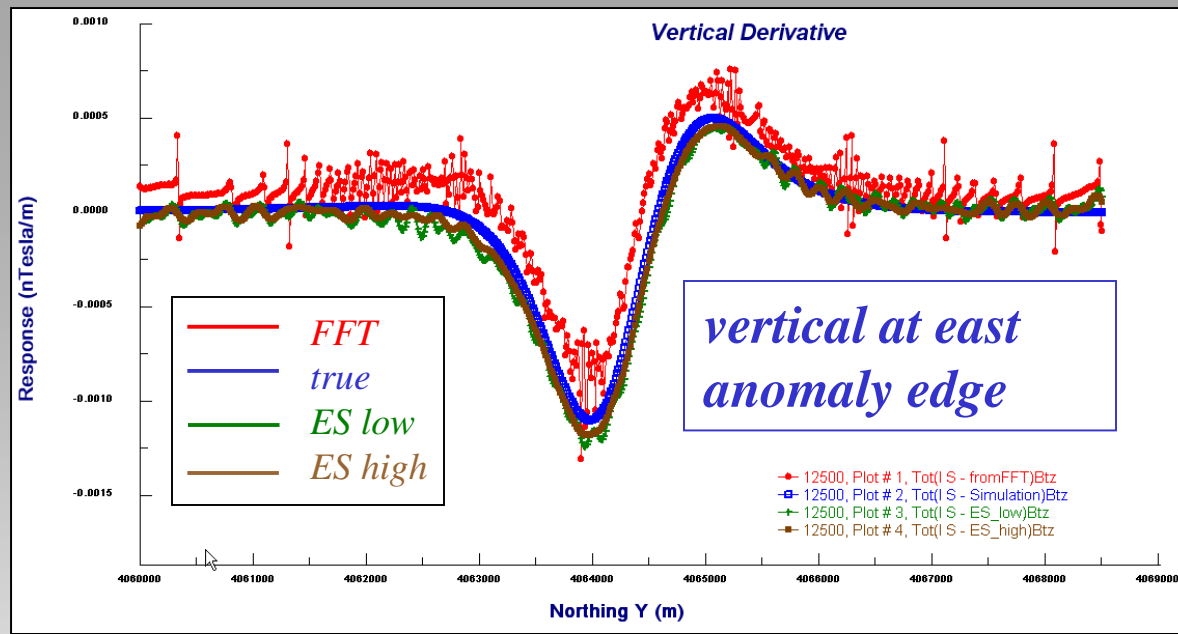

FFT noise due to elevation variation interpolation

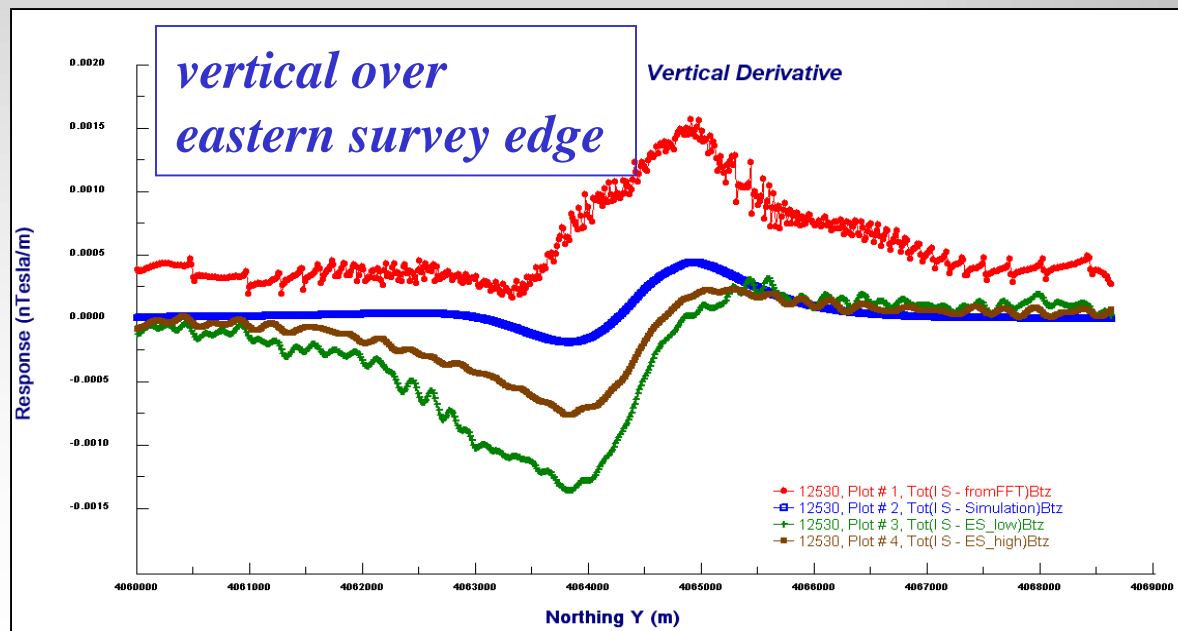

Model 3

Add a small object to model 1

Added Gaussian noise of standard deviation of 5nT to simulated data

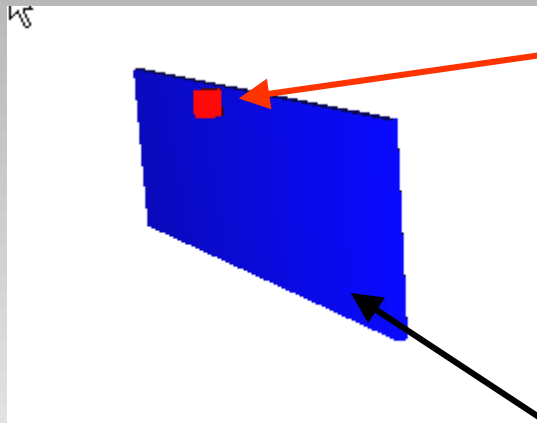

Properties of small object

Dimension: 150m by 150m by 40m

Depth to top: 50m

Susceptibility: 0.05

Properties of big object

Dimension: 3000m by 1000m by 50m

Depth to top: 50m

Susceptibility: 0.1

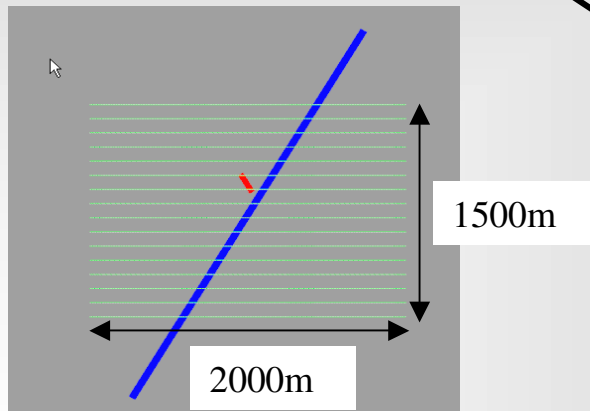

plane view

Crossline Derivatives

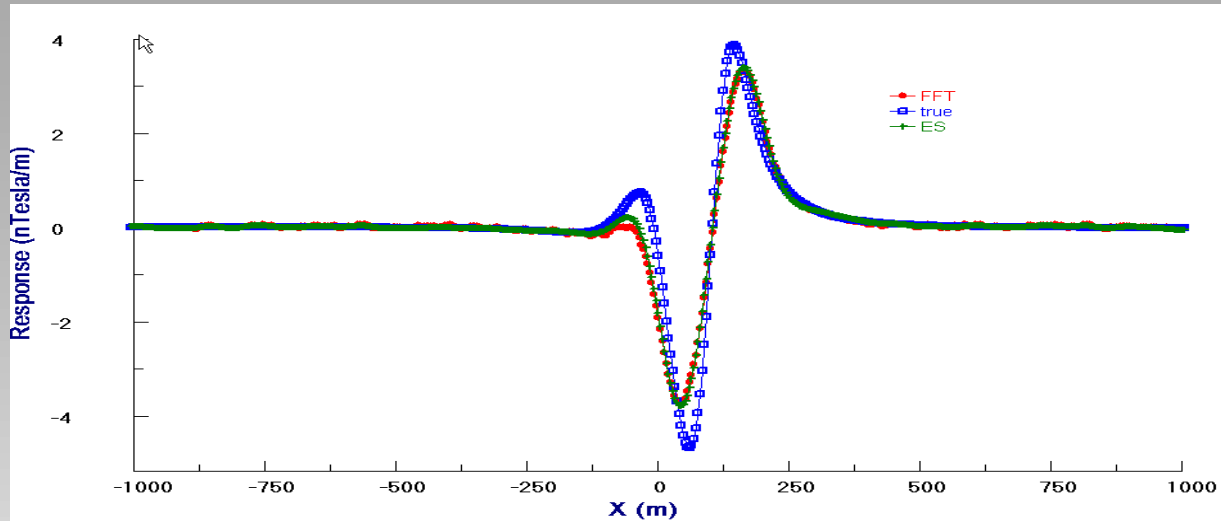

Crossline derivatives along the line at the south edge of the small anomaly

Red: FFT via minimum curvature.. Blue: true. Green: equivalent source.

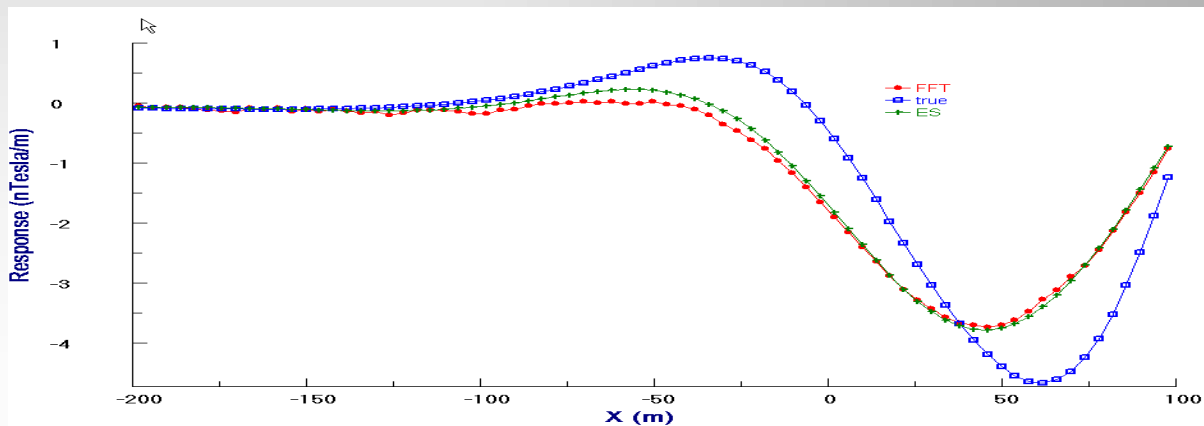

Zoom-in view

Conclusions

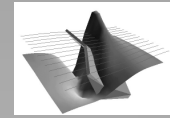

- **ES has less edge effects than FFT.**
- **ES incorporates variation of the elevation of sensor in processing derivatives.**